

# OPERATOR'S MANUAL



**ES-1000**

Serial Number 025000 & Up

**ES-2000**

Serial Number 001001 & Up

**WARNING ▲ DANGER**

READ INSTRUCTIONS CAREFULLY AND  
FOLLOW RULES FOR SAFE OPERATION.  
FAILURE TO DO SO COULD RESULT IN  
SERIOUS INJURY.

---

---

The ECHO logo is rendered in a bold, italicized, sans-serif font with a thick outline. The letter "E" is stylized with three parallel diagonal lines on its left side. A registered trademark symbol (®) is located at the bottom right of the "O".

---

---

For your nearest ECHO Dealer, call 1-800-432-ECHO (3246)

# INTRODUCTION

The ECHO ES-1000 and ES-2000 SHRED-N-VAC™ are lightweight, high performance, gasoline powered units designed for vacuuming and shredding a wide variety of debris.

This manual provides the information necessary for operation and maintenance.

## **WARNING** **DANGER**

Improper use or care of this unit, or failure to wear proper protection can result in serious injury. Read and understand the rules for safe operation and all instructions in this manual. Wear eye and hearing protection.

# SAFETY AND SPECIAL INFORMATION

## **WARNING** **DANGER**

This symbol is used to call attention to procedures that must be followed to avoid the risk of serious, immediate and irreversible human injury or death

## **IMPORTANT**

Indicates a situation that may cause damage to equipment.

## **NOTE**

Draws attention to special information.

- Read and understand the entire operator's manual before using this machine.
- Follow all danger warnings in this manual.
- Locate the safety decals on your unit. Make sure the decals are legible and that you understand and follow them.

# CONTENTS

	Page No.
Safety.....	1
Description .....	3
Fuel .....	4
Operation .....	5
Service Maintenance Guide.....	7
Troubleshooting.....	7
Service .....	8
Assembly.....	11
Storage.....	12
Specifications.....	13

Specifications, descriptions and illustrative material in this literature are as accurate as known at the time of publication, but are subject to change without notice. Illustrations may include optional equipment and accessories, and may not include all standard equipment.

# SAFETY

## WARNING DANGER

Users risk injury to themselves and others if the unit is used improperly, and/or safety precautions are not followed. Proper clothing and safety gear must be worn when operating SHRED-N-VAC™.

## OPERATOR SAFETY

- Read this Operator's Manual carefully. Be sure you understand how to operate this unit properly before you use it.
- Wear non-skid sole shoes. Do not wear open-toed shoes or operate unit while bare footed.
- Wear proper clothing to protect legs and other exposed parts of your body.
- Wear eye, breathing and hearing protection devices.
- Use caution when handling fuel. Put the gas caps back tightly on both the gas can and the fuel tank. Move at least 10 feet from the refueling point and be sure there is no leakage of fuel from the gas cap or the fuel system before starting the engine.
- Operate this gasoline engine powered equipment in a well-ventilated area only.

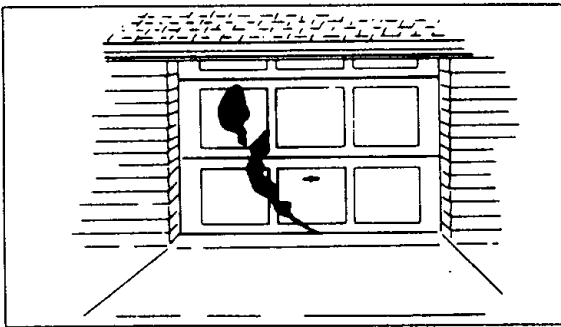

- Start the unit on the ground with the throttle set at idle. Do not start if the pipe is obstructed by the ground or any other object.
- Inspect area where SHRED-N-VAC™ will be used. Remove stones, metal objects and any other object that could cause injury or damage.
- Be certain the safety interlock switch operates correctly (unit must stop when vacuum pipe is removed or fan guard is opened).
- Do not allow other persons or pets in the area when starting or using the SHRED-N-VAC.
- Keep a firm grip on the SHRED-N-VAC™ at all times.

## REDUCE NOISE

### NOTE

Before operating the unit, check and follow local regulations concerning sound level and hours of operation.

- Avoid using when people are likely to be disturbed, such as late at night or early in the morning. As a rule, operate between 8 a.m. and 5 p.m. on weekdays and 9 a.m. to 5 p.m. weekends.
- Operate at the lowest possible throttle setting that gets the job done. If you loosen compacted leaves, grass or debris with a broom or a rake, using full throttle is not necessary.
- Make sure the muffler works well. Also check the air intakes and the air filter.
- Use only one piece of equipment at a time.

## PROTECTIVE EQUIPMENT

- Always wear eye protection goggles that meet ANSI Z 87.1 requirements (Z87 is stamped on the goggles).
- Wear hearing protection at all times. If this guideline is not followed, hearing loss can occur.
- Wear snug fitting, durable clothing. Avoid wearing loose clothing or accessories that could become entangled and cause injury.
- Wear shoes with non-skid soles to ensure proper footing.
- Wear non-slip, heavy-duty work gloves to improve your grip. The gloves also help reduce the transmission of machine vibrations to your hands.
- Always use a filter mask to avoid breathing dust.

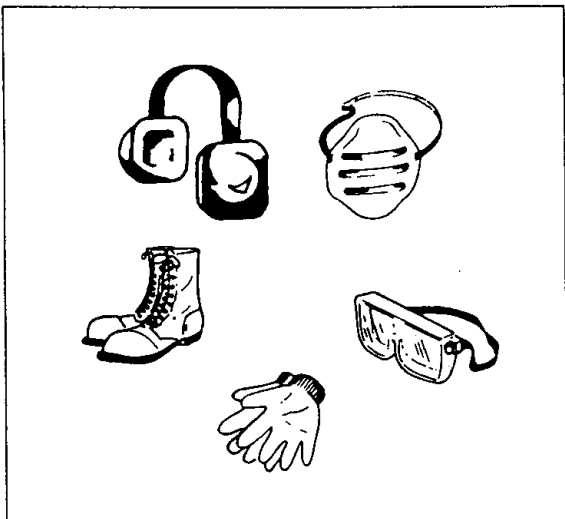

## PROTECTING OTHERS

Spectators, children, fellow workers and animals must be warned to come no nearer than 50 feet while the unit is in use. People working in the area near you should wear the same protective equipment as the operator.

## PHYSICAL CONDITION

Your judgement and dexterity may be impaired if you are ill or have taken alcohol or other substances known to affect the way you would normally function. Operate only when your mind and body are sound.



### **WARNING ▲ DANGER** **PRECAUTION AGAINST** **VIBRATION AND COLD**

It is believed that a condition called Raynaud's Phenomenon which affects the fingers of certain individuals is brought about by exposure to cold and vibration. Exposure to cold and vibration may cause tingling and burning, followed by loss of color and numbness in a person's fingers. We strongly recommend taking the following precautions because the minimum exposure which might trigger the ailment is unknown.

- Keep your body warm - especially head, neck, feet and ankles, and hands and wrists.
- Maintain good blood circulation by performing vigorous arm exercises during frequent work breaks, and also by not smoking.
- Limit the number of hours of operation. Try to fill a part of each work day with jobs where operating hand-held power tools is not required.
- If you experience discomfort, redness and swelling of the fingers, followed by whitening and loss of feeling, consult your physician before exposing yourself further to cold and vibration.

# DESCRIPTION

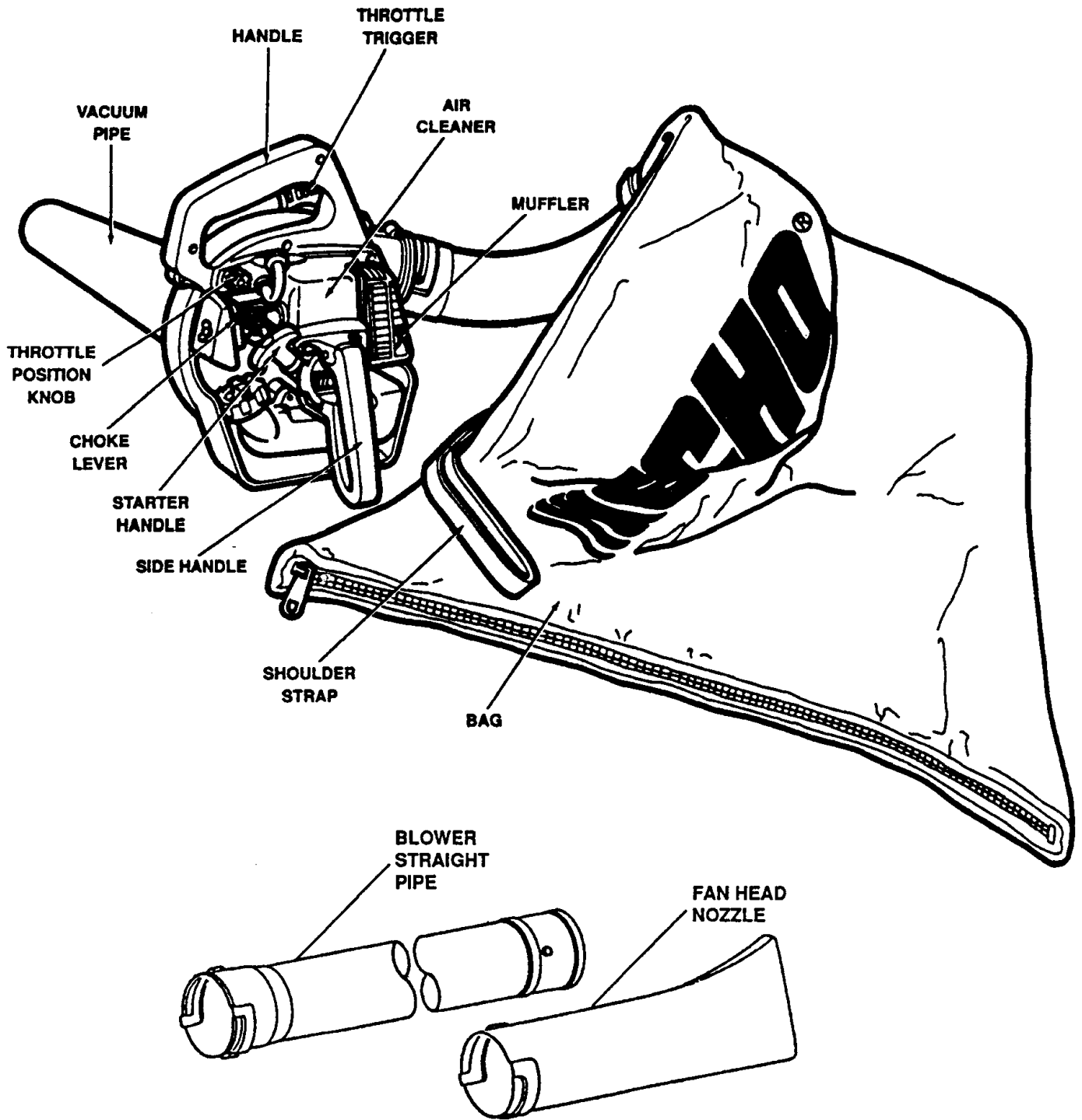

# FUEL

## HANDLING FUEL

### **WARNING ▲ DANGER**

Handle fuel carefully. It is extremely flammable. Follow all rules listed below to help prevent fire or explosion which may result in severe injury or death.

- Never smoke or allow flame or sparks near fuel.
- Always fill the fuel tank outdoors. Never pour fuel indoors.
- Never refuel the engine when it is hot or running.
- Always use an approved, safe fuel container.
- After fueling, always wipe up spilled fuel.
- Do not overfill the tank. Always move at least 10 feet away from the fueling spot and make sure there is no fuel leakage before starting the engine.

- Never store the blower with fuel in the tank - a fuel leak could start a fire. Store fuel in an approved container.
- Always remove the fuel cap slowly to relieve any pressure buildup in the tank.
- Always tighten fuel caps on blower and fuel container.

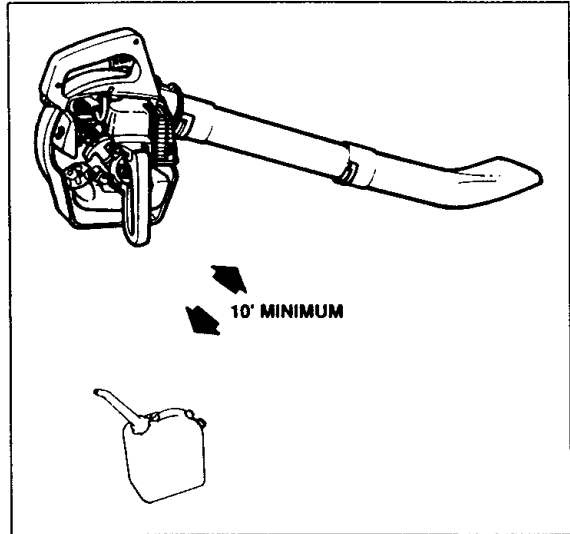

## FUEL

The engine uses two-stroke fuel, a mixture of gasoline and specially blended Echo branded 2-stroke oil. 50:1 preferred, 32:1 alternate choice.

### **GASOLINE**

Use branded 89 octane  $\frac{R+M}{2}$  unleaded gasoline or gasohol (maximum 10% ethyl alcohol, no methyl alcohol).

### **MIXING FUEL**

Follow directions on oil container.

## STORING FUEL

Store fuel only in clean, safe, approved containers. Check and follow local ordinances on type and location of storage containers.

### **IMPORTANT**

Two-stroke fuel may separate. Shake fuel container thoroughly before each use.

### **IMPORTANT**

Stored fuel ages. Do not mix more fuel than you expect to use in a month.

# OPERATION

## IMPORTANT

Recoil starter: Use short pulls - only 1/2-2/3 of starter rope for starting. Do not allow the rope to snap back in. Always hold the unit firmly.

## IMPORTANT

• Check unit for loose nuts, bolts and screws daily.

## STARTING COLD ENGINE

1. Move ignition switch to START/RUN position.

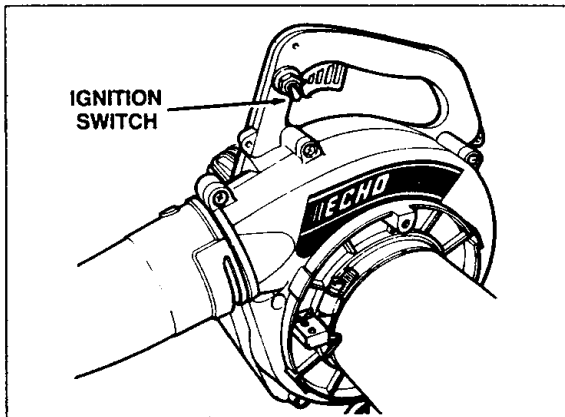

2. Push purge bulb 3 to 4 times (or until fuel is visible in fuel return line).

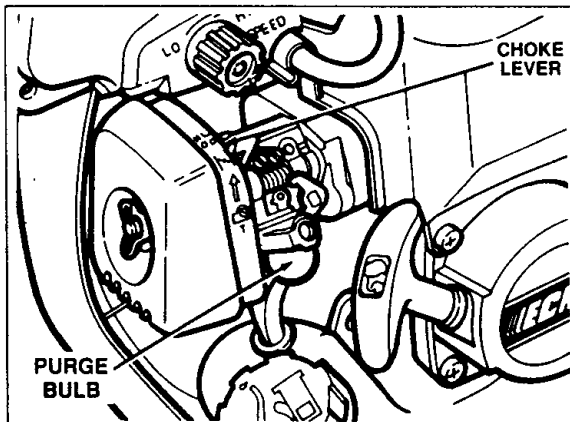

3. Close choke and pull starter handle until engine fires.

## STARTING WARM ENGINE

1. Move ignition switch to start, pull starter one to three times and engine should fire. Do not use choke.

## NOTE

If engine does not start after 3 pulls, use cold start procedure.

## STOPPING ENGINE

1. Release throttle trigger and allow engine to run at idle for a few minutes.
2. Move ignition switch to "stop" position.

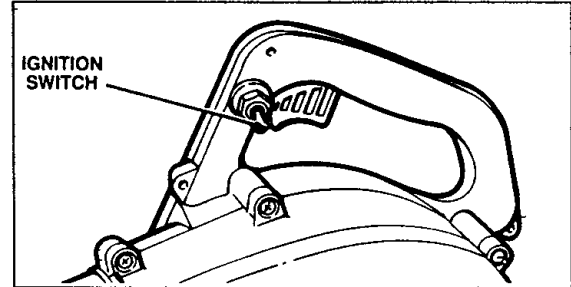

## WARNING DANGER

If engine does not stop, shift choke lever to closed position.

Check and repair ignition switch before starting engine again.

## OPERATING SHRED-N-VAC™

### WARNING ▲ DANGER

- Always wear safety glasses and use a face filter mask. (Read the Safety Section carefully.)

### IMPORTANT

Do not block vacuum pipe to avoid engine damage due to over revving.

1. Allow the engine to warm up at a fast idle for a few minutes.

#### NOTE

The ECHO SHRED-N-VAC™ can be run at any speed between 2500 RPM to 7000 RPM. The vacuum can, therefore, be easily controlled from a mild vacuum for small leaves to maximum suction for larger leaves and twigs. For maximum shredding a higher speed setting is required.

#### NOTE

Never use a higher speed setting than necessary to perform a task. Remember, the higher the engine speed, the louder the vacuum noise.

2. Set engine speed with throttle position knob.

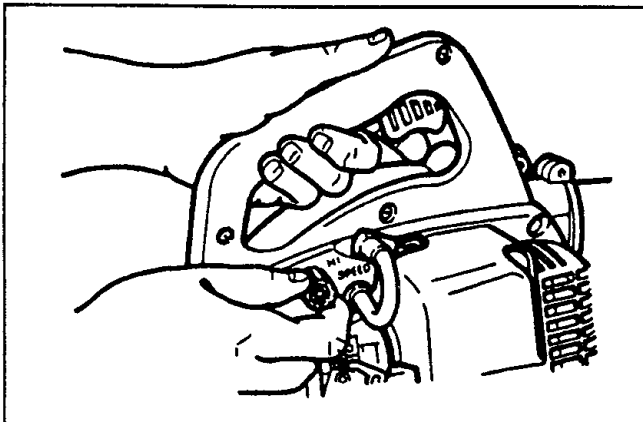

3. Place shoulder harness over right shoulder.



4. Make sure bevel at end of pipe faces downward.

## OPERATING BLOWER

### WARNING ▲ DANGER

- Always wear safety glasses and use a face filter mask. (Read the Safety Section carefully.)
- Do not point the blower pipe in the direction of people or pets.
- Never operate unit without housing cover grill secured by thumb nut otherwise bodily harm may result.

### IMPORTANT

Do not block blower pipe to avoid engine damage due to over revving.

1. Allow the engine to warm up at a fast idle for a few minutes.
2. Set engine speed with throttle position knob.

#### NOTE

The ECHO SHRED-N-VAC™ can be run at any speed between 2500 RPM to 7000 RPM. The velocity of the air stream can, therefore, be easily controlled from a mild flow to high speed blast which will move debris ranging from garden leaves to bottles and other debris.

#### NOTE

Never use a higher speed setting than necessary to perform a task. Remember, the higher the engine speed, the louder the blower noise.

#### NOTE

Use a low speed to blow dry leaves from a lawn or flower bed. Additional speed may be necessary to clean grass and leaves from walks, patios and drives or to move gravel, dirt, snow, bottles or cans from a driveway, street or parking lot.



# SERVICE MAINTENANCE GUIDE

AREA	MAINTENANCE	PAGE	BEFORE USE	MONTHLY	YEARLY
Screws, Bolts & Nuts	Inspect, Tighten/ Replace		●		
Fuel Line	Inspect			●	
Air Filter	Clean/Replace	8	●		
Fuel Filter	Inspect/Replace	10		●	
Spark Plug	Inspect/Clean/ Adjust/Replace	10		●	
Carburetor	Adjust	8			●
Cooling System	Inspect/Clean	9	●		
Muffler (Spark Arrestor)	Inspect/Clean	9		●	
Vacuum Bag	Inspect/Clean	10	●		
Starter Rope	Inspect/Replace			●	
Shredder Blade	Inspect/Clean	10	●		
Fuel Leaks	Inspect/Repair		●		

## IMPORTANT

Time intervals shown are maximum. Actual use and your experience will determine the frequency of required maintenance.

# TROUBLESHOOTING

Problem		Cause	Remedy	
Engine —starts hard —does not start				
Engine Cranks	Fuel at carburetor	No fuel at carburetor	<ul style="list-style-type: none"> <li>•Fuel strainer clogged</li> <li>•Fuel line clogged</li> <li>•Carburetor</li> </ul>	<ul style="list-style-type: none"> <li>•Clean.</li> <li>•Clean.</li> <li>•See your Echo dealer</li> </ul>
	Fuel at cylinder	No fuel at cylinder	•Carburetor	•See your Echo dealer
		Muffler wet with fuel	•Fuel mixture is too rich	<ul style="list-style-type: none"> <li>•Open choke</li> <li>•Clean/replace air filter</li> <li>•Adjust carburetor</li> <li>•See your Echo dealer</li> </ul>
	Spark at end of plug wire	No spark at end of plug wire	<ul style="list-style-type: none"> <li>•Ignition switch off</li> <li>•Electrical problem</li> <li>•Interlock switch</li> </ul>	<ul style="list-style-type: none"> <li>•Turn switch on</li> <li>•See your Echo dealer</li> <li>•See your Echo dealer</li> </ul>
	Spark at plug	No spark at plug	<ul style="list-style-type: none"> <li>•Spark gap incorrect</li> <li>•Covered with carbon</li> <li>•Fouled with fuel</li> <li>•Spark plug defective</li> </ul>	<ul style="list-style-type: none"> <li>•Adjust. 0.6-0.7 mm (0.024-0.028)</li> <li>•Clean or replace.</li> <li>•Clean or replace.</li> <li>•Replace plug</li> </ul>
Engine does not crank		•Internal engine problem	•See your Echo dealer	
Engine runs	Dies or Accelerates poorly	<ul style="list-style-type: none"> <li>•Air filter dirty</li> <li>•Fuel filter dirty</li> <li>•Fuel vent plugged</li> <li>•Spark plug</li> <li>•Carburetor</li> <li>•Cooling system plugged</li> <li>•Exhaust port/spark arrestor screen plugged</li> </ul>	<ul style="list-style-type: none"> <li>•Clean or replace</li> <li>•Replace</li> <li>•Plugged</li> <li>•Clean and adjust/replace</li> <li>•Adjust</li> <li>•Clean</li> <li>•Clean</li> </ul>	

# SERVICE

## AIR FILTER

**NOTE**  
Clean daily.

1. Close choke, remove wing nut, air cleaner cover and air filter.
2. Brush dust off filter and wash in suitable solvent.
3. Dry filter before reinstalling.

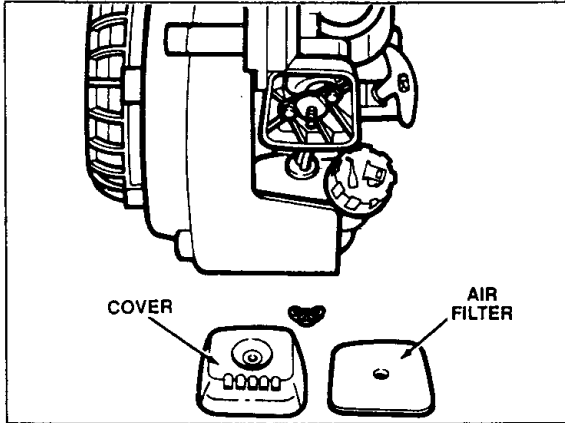

## ADJUSTING CARBURETOR

### General

**NOTE**  
Do not adjust carburetor unless necessary. If you have trouble with carburetor, see your dealer. Always adjust carburetor with pipes assembled to the blower.

The idle speed adjustment screw controls the throttle opening at idle position.

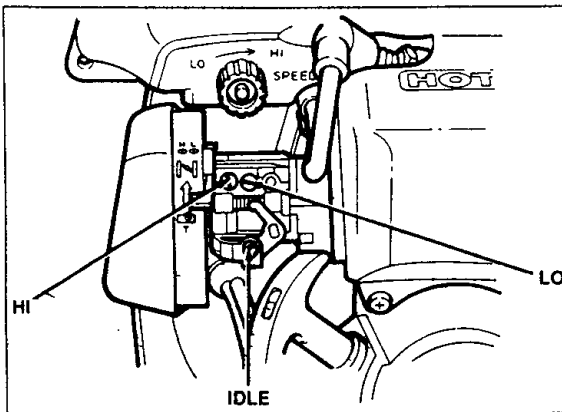

The low (LO) speed adjustment screw controls the volume of fuel/oil mixture at low engine speed. It also controls the supplementary fuel required to obtain smooth progression from idling to high speed.

The high (H) speed adjustment screw controls the volume of fuel/oil mixture at full throttle.

### Initial Adjustment

**NOTE**  
The needle screws have a sharp point. To avoid carburetor damage, do not use excessive force when seating needle in body.

1. Turn HI and LO adjustment screws clockwise until seated lightly in carburetor body.
2. Turn LO adjustment screw counterclockwise 1 1/4 turn.
3. Start engine and allow it to run at high idle until warm (approx. 2-3 minutes).

**NOTE**  
Idle speed screw may have to be readjusted to keep engine from stalling.

### Low Speed Adjustment

1. Slowly turn the LO adjustment screw clockwise and note the position when the engine speed drops.
2. Turn the LO adjustment screw counterclockwise and note position when engine speed drops.
3. Set the screw midway between these points.
4. Turn idle speed clockwise until a speed of 2500-3400 RPM is achieved and engine idles without stalling.

### High Speed Adjustment

**NOTE**  
Engine must be at normal operating temperature.

1. Turn the HI adjustment screw counterclockwise 1 1/4 turn.
2. While running the engine at full throttle, turn the HI adjustment screw slowly clockwise until the engine runs smoothly.

3. Turn the screw counterclockwise  $\frac{1}{8}$  turn to obtain optimum fuel mixture for full power under load conditions.
4. If engine hesitates during acceleration from idle to full throttle, turn HI speed screw  $\frac{1}{8}$  to  $\frac{1}{4}$  of a turn counter clockwise.

## COOLING SYSTEM MAINTENANCE

### IMPORTANT

To maintain proper engine operating temperatures, cooling air **must** pass freely through the cylinder fin area. This flow of air carries combustion heat away from the engine.

Overheating and engine seizure can occur when:

- Air intakes are blocked preventing cooling air from reaching the cylinder, or
- Dust and grass build up on the outside of the cylinder. This build up insulates the engine and prevents the heat from leaving.

Removal of cooling passage blockages or cleaning of cylinder fins is considered "Normal Maintenance." Any resultant failure attributed to lack of maintenance is not warranted.

The cooling system relies on cooling air entering the engine through a grille located between the fuel tank and starter.

The cooling fan pushes this air through the cylinder area and out the forward facing opening in the engine cover.

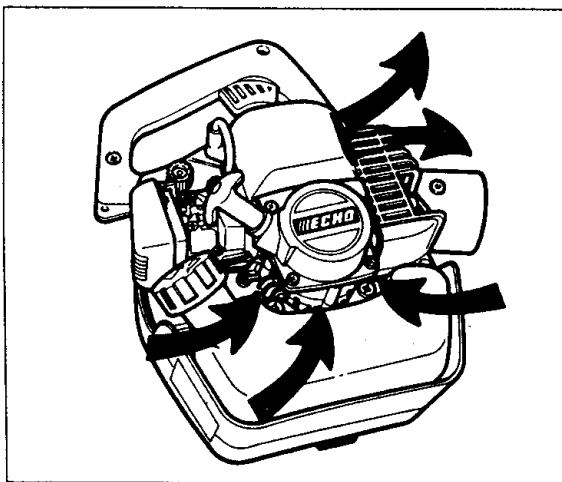

## Cleaning

1. Remove accumulated debris from intake grille.

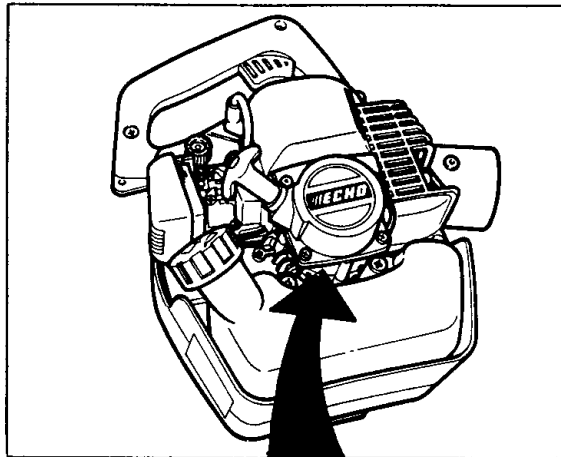

## MUFFLER AND EXHAUST PORT

### NOTE

Carbon deposits in cylinder exhaust port and muffler will cause a drop in engine output and overheating. Muffler exhaust port and spark arrestor screen must be checked.

1. Remove muffler cover, gasket and muffler.
2. Clean cylinder exhaust port being careful not to scratch cylinder or piston.
3. Remove spark arrestor cover and spark arrestor screen from muffler. Replace screen if plugged with carbon deposits.
4. Install spark arrestor screen, gasket and cover.
5. Install muffler, gasket and cover.

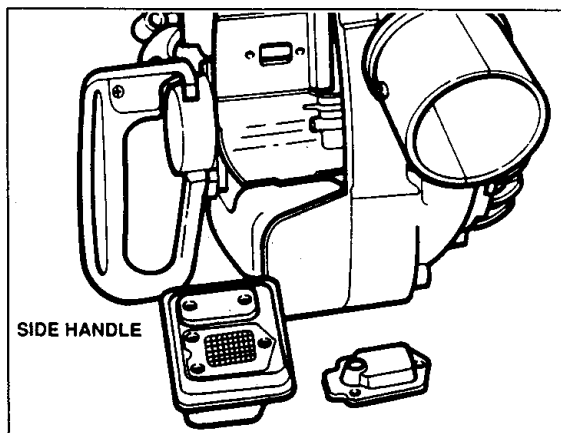

## SPARK PLUG

1. Clean stains or carbon off spark plug.
2. Adjust spark plug gap to 0.6 - 0.7 mm (0.023 - 0.028 in.).
3. Tighten spark plug to 145-155 kg/cm (125-135 in. lb.).

### IMPORTANT

Do not overtighten spark plug.

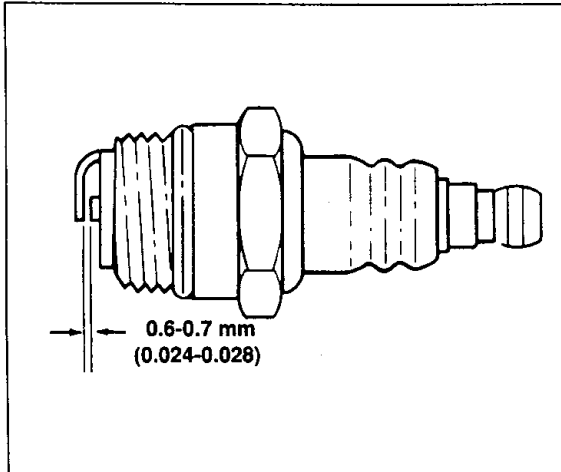

## FUEL FILTER

### IMPORTANT

Keep fuel tank clean - do not allow dirt or debris to enter fuel tank.

### NOTE

A clogged fuel filter will cause hard starting or poor engine performance.

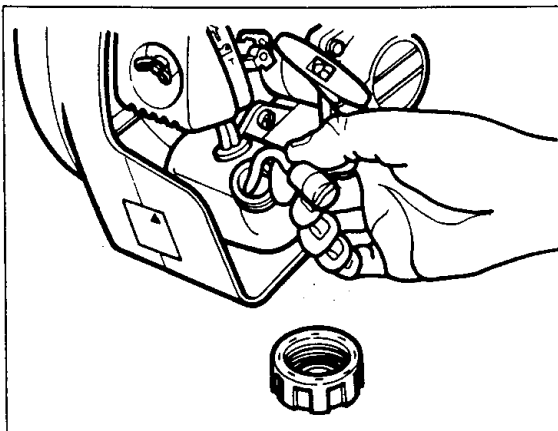

1. Pick up the fuel filter through fuel tank opening with a piece of steel wire.
2. Remove old filter.
3. Install new filter.

## SHREDDER BLADE

### WARNING DANGER

Never remove vacuum tube or open fan guard when SHRED-N-VAC™ is running.

1. With engine stopped, remove spark plug wire, loosen clamp and pull vacuum tube from unit.
2. Remove accumulated debris from blade and inspect for damage.

### IMPORTANT

Do not operate SHRED-N-VAC™ if shredder blade is damaged, loose or broken.

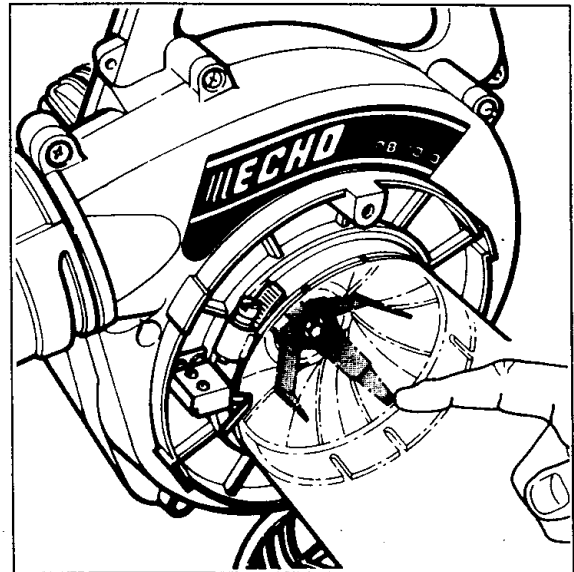

3. Refer to "Installing Vacuum Tube" in assembly section for correct reassembly procedures.

## VACUUM BAG

Shake dust from bag and inspect for holes or tears. Inspect zipper and clean debris from teeth to assure complete closing of zipper.

# ASSEMBLY

## WARNING ▲ DANGER

Never perform maintenance or assembly procedures with engine running.

## IMPORTANT

Never operate unit without either housing over or vacuum tube installed securely on unit.

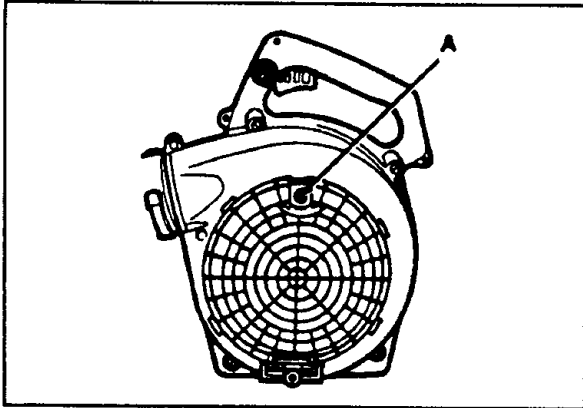

## INSTALLING VACUUM TUBE

1. Turn knob (A) counterclockwise until housing cover is free. Pull fan guard out for access to tube clamp (B).

### NOTE

The tube will contact the switch tab when properly assembled onto the blower. A "click" will be heard indicating the switch is activated allowing the unit to operate. If the engine does not start, recheck the tube mounting for straightness and engagement with the blower housing.

2. Hold the housing cover open, and slide the vacuum tube into the housing mount until completely seated. Position the tube so that the bevel faces down in the operating position.

## WARNING ▲ DANGER

This unit is equipped with a safety switch (C) which allows the engine to start or run only when the fan guard is in place or the vacuum tube is installed. Never bend or disable this switch and operate the unit; otherwise severe injury may result.

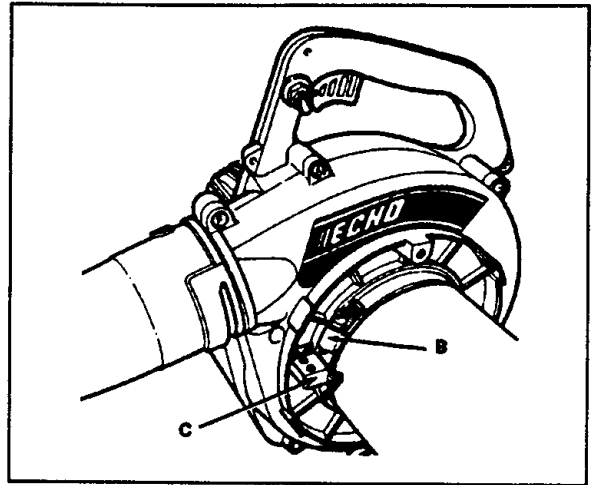

3. Secure vacuum tube with clamp (B).  
Note: Make sure that the clamp fits under the slotted guide.
4. Align grooves in vacuum elbow with pegs on air outlet and install vacuum elbow.
5. Turn vacuum elbow clockwise to lock it into place.

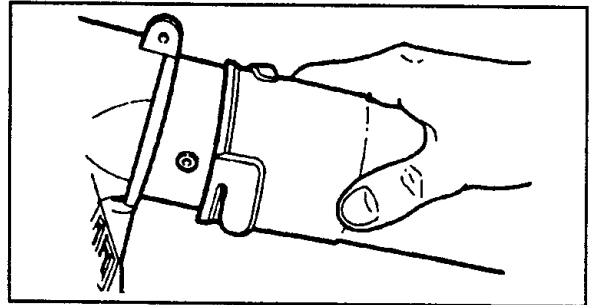

6. Place vacuum bag opening over end of vacuum elbow and secure with velcro straps.

## INSTALLING BLOWER PIPES

## WARNING ▲ DANGER

Never perform maintenance or assembly procedures with engine running.

1. Align grooves in straight pipe with pegs on blower housing and slide pipe onto housing.
2. Turn straight pipe clockwise to lock it into place.
3. Align grooves in fan head nozzle with pegs on straight pipe and slide fan head nozzle onto straight pipe.
4. Turn fan head nozzle clockwise to lock it into place.

# STORAGE

## LONG TERM STORAGE (OVER 60 DAYS)

Do not store your unit for a prolonged period of time (60 days or longer) without performing protective storage maintenance which includes the following:

1. Store unit in a dry, dust free place, out of the reach of children.

### **WARNING** **DANGER**

Do not store in enclosure where fuel fumes may accumulate or reach an open flame or spark.

2. Place the ignition switch in the "STOP" position.

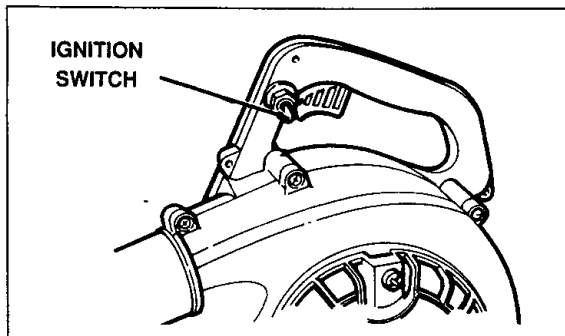

3. Remove accumulation of grease, oil, dirt and debris from exterior of unit.
4. Perform all periodic lubrication and services that are required.
5. Tighten all the screws and nuts.

6. **Drain** the fuel tank **completely** and pull the starter handle several times to remove fuel from the carburetor.
7. Remove the spark plug and pour 1/4 oz. (1/2 tablespoon) of fresh, clean, 2-stroke engine oil into the cylinder through the spark plug hole.
  - A. Place a clean cloth over the spark plug hole.
  - B. Pull the recoil starter handle 2-3 times to distribute the oil inside the engine.

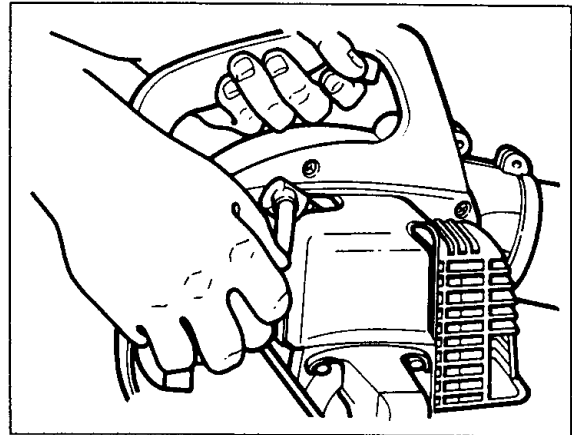

- C. Observe the piston location through the spark plug hole. Pull the recoil handle slowly until the piston reaches the top of its travel and leave it there.
8. Install the spark plug (do not connect ignition cable.)

# SPECIFICATIONS

## MODEL ES-1000

Dimensions	Length	340 mm (13.39 in.) w/o vacuum attachment
	Width	285 mm (11.22 in.) w/side handle
	Height	375 mm (14.76 in.)
Weight (Dry, with pipe, handle and bag)		4.8 kg. (10.6 lbs.)
Engine	Type	Air cooled, two stroke single-cylinder gasoline engine
	Bore	32.2 mm (1.268 in.)
	Stroke	26.0 mm (1.024 in.)
	Displacement	21.2 cc (1.29 cu. in.)
Exhaust System		Spark arrester muffler
Carburetor		ZAMA diaphragm model CIU type w/purge
Ignition System	Type	Flywheel Magneto, C.D.I. (Capacitive discharge ignition)
	Spark Plug	NGK BPM-7A, Champion CJ-7Y
Fuel System	Fuel	Mixed, using ECHO brand, two-stroke air cooled engine oil and minimum 89 octane gasoline. Do not use gasoline containing methylalcohol or more than 10% ethylalcohol.
	Fuel/Oil Ratio	32:1 or 50:1 ratio with ECHO oil
	Fuel Tank Capacity	0.5 lit. (17.0 US fl. oz.)
Starter System		Automatic rewind system
Blower	Type	Centrifugal (single stage)
	Max RPM	7000
	Air Volume	283 cu. ft/min w/straight pipe
	Max Air Speed	106.6 MPH w/straight pipe

## MODEL ES-2000

Dimensions	Length	340 mm (13.39 in.) w/o vacuum attachment
	Width	300 mm (11.81 in.) w/side handle
	Height	375 mm (14.76 in.)
Weight (Dry, with pipe, handle and bag)		4.89 kg. (10.7 lbs.)
Engine	Type	Air cooled, two stroke single-cylinder gasoline engine
	Bore	34.0 mm (1.34 in.)
	Stroke	26.0 mm (1.024 in.)
	Displacement	23.6 cc (1.44 cu. in.)
Exhaust System		Spark arrester muffler
Carburetor		ZAMA diaphragm model CIU type w/purge
Ignition System	Type	Flywheel Magneto, C.D.I. (Capacitive discharge ignition)
	Spark Plug	NGK BPM-7A, Champion CJ-7Y
Fuel System	Fuel	Mixed, using ECHO brand, two-stroke air cooled engine oil and minimum 89 octane gasoline. Do not use gasoline containing methylalcohol or more than 10% ethylalcohol.
	Fuel/Oil Ratio	32:1 or 50:1 ratio with ECHO oil
	Fuel Tank Capacity	0.5 lit. (17.0 US fl. oz.)
Starter System		Automatic rewind system
Blower	Type	Centrifugal (single stage)
	Max RPM	7600
	Air Volume	325 cu. ft/min. w/straight pipe
	Max Air Speed	114 MPH w/straight pipe

## PARTS BOOKS

To obtain a replacement parts book, complete this order form and enclose a check or money order for \$2.00. Make payable to ECHO, INCORPORATED, and mail to:

ECHO, INCORPORATED  
P.O. Box 67  
Lake Zurich, IL 60047  
ATTN: Technical Publications

\_\_\_\_\_  
Purchaser's Name

\_\_\_\_\_  
Address (Street)

\_\_\_\_\_  
(City)

(State)

(Zip Code)

ECHO Model No. SHRED-N-VAC™ ES-1000  
Parts Book No. 999222 01982

ECHO Model No. SHRED-N-VAC™ ES-2000  
Parts Book No. 999222 02283



**ECHO, INCORPORATED**  
400 OAKWOOD ROAD • LAKE ZURICH, IL 60047  
PHONE: 708-540-8400

X7501132500

**999222 02282**  
Printed in U.S.A.  
6/94